

VMECA VACUUM CARTRIDGE

VC102

Features and Strengths

- Two stage – VMECA micro cartridge
- The most compact size multi stage vacuum ejector
- High vacuum level (-83 kPa) at low air pressure
- Extremely low air consumption
- Reliable performance despite inconsistent compressed air pressure
- International patent



Specifications

Description	VC102
Max. Vacuum level	-83 kPa
Open Vacuum flow	16 NI/min
Max. Feed pressure	7 bar
Temperature	-20 ~ 80 °C
Material	PPS, POM, NBR, AL(Holding plug)
Weight	0.7 g

Vacuum Flow

Model	Max. vacuum (-kPa)	Feed Pressure (bar)	Vacuum flow (NI/min) at different vacuum levels (-kPa)									
			0	10	20	30	40	50	60	70	80	90
VC102	50	1.1	11.5	6.3	2.2	1.6	0.7	-	-	-	-	-
	83	1.8	14.2	9.4	3.3	2.2	2	1.4	0.8	0.4	0.18	-
	83	2.2	16	11.9	5.1	2.3	1.4	1.3	0.9	0.3	0.12	-

Evacuation Time

Model	Feed Pressure (bar)	Air Consumption (NI/min)	Evacuation time in sec / liter to reach different vacuum levels (-kPa)									
			10	20	30	40	50	60	70	80	90	
VC102	1.1	5.9	0.68	3	6.1	11.8	27.2	-	-	-	-	
	1.8	8.2	0.4	1.48	4.3	6.9	9.1	15.3	27.4	50.2	-	
	2.2	10	0.34	1.6	3.9	7	10.4	17.5	30.9	61.4	-	

Build an Ordering No.

1. Cartridge	Description	Ordering No.
	Micro vacuum cartridge, 2-stage	VC102
	Micro vacuum cartridge, 2-stage, Holding plug	VC102P

Spare Parts – Plug

Model	Description	Weight (g)
VCP-M7	Holding plug	0.8

Dimension - Basic Pump

[Unit : mm]

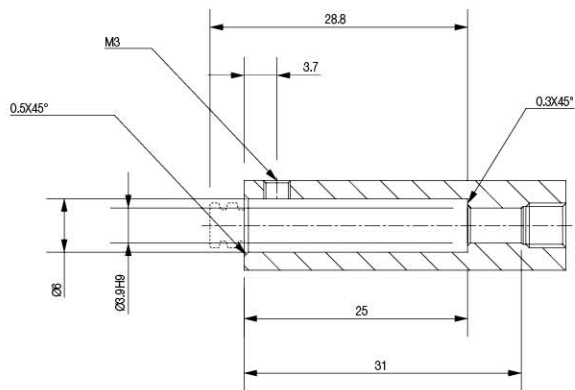
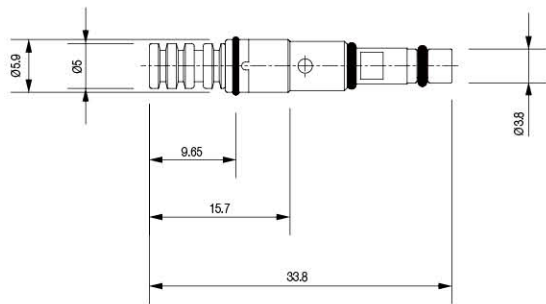

VC102

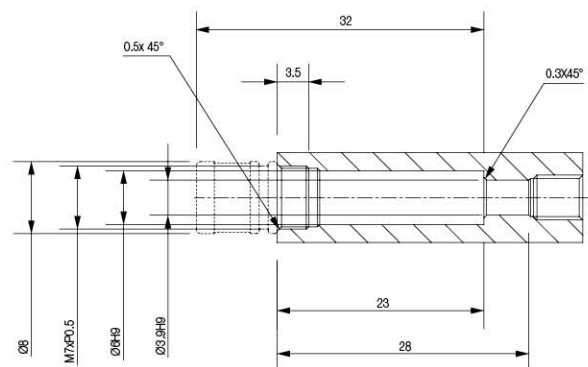

VC102P